

# Spiral Dance 4-Piece Stage Plan

## **Spiral Dance are:**

Adrienne Piggott – lead vocals  
Nick Carter – guitars; didgeridoo; vocals  
Paul Gooding – button accordion; vocals  
Rick Kearsley – drums

## **Requirements:**

3 x Vocal mics  
1 x Instrument Mic  
1 x Kick Mic  
2 x DI boxes  
2 x XLR  
2 x AC Power

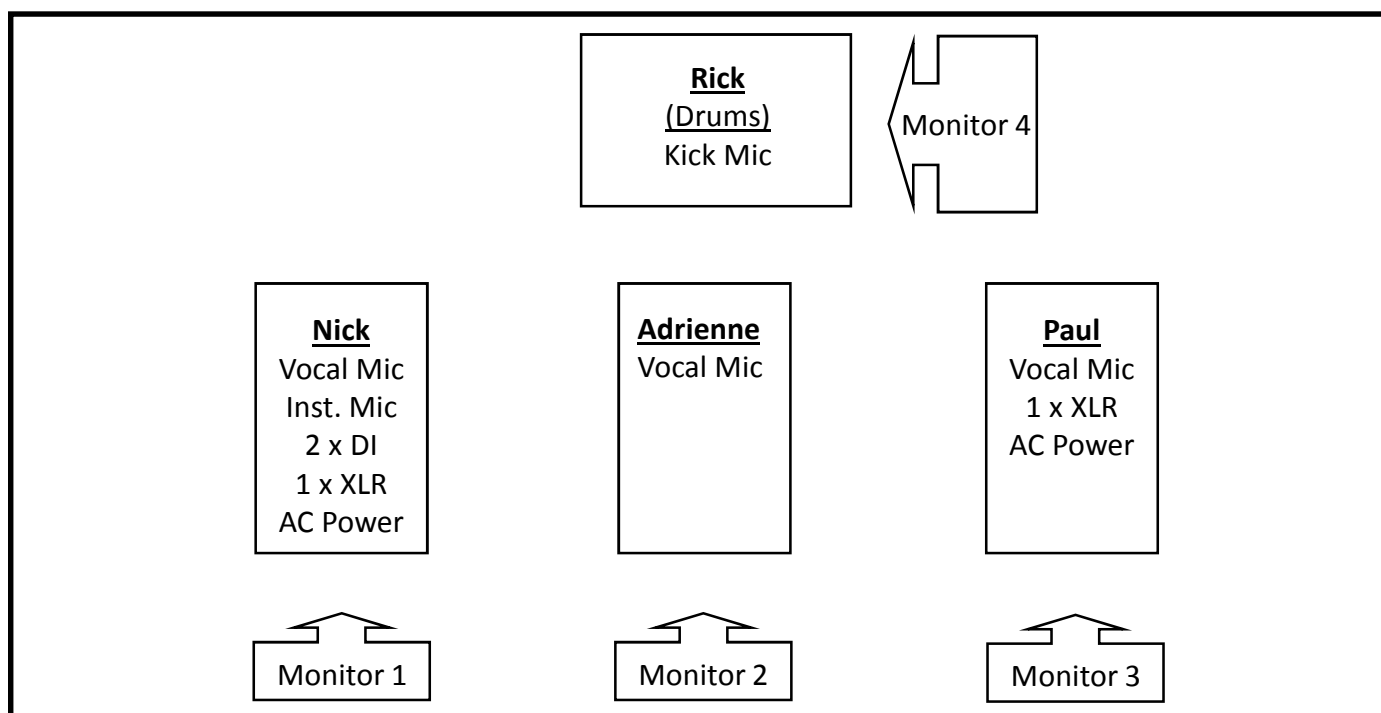

## Front of Stage

### **YOUR PA SYSTEM:**

- \* We ideally need 9 inputs (as shown above).
- \* Good monitoring is essential; we prefer 3 monitors with at least 2 separate sends.
- \* 31 Band Graphic EQ for 2 sends and front of house...total of 3 EQs if not running in stereo.
- \* Reverb effects are essential for vocals.
- \* Microphones: we need 3 x Shure SM58 mics (or better) on stands for vocals, boom stands very much preferred. We also require 1 x instrument mic (Shure SM57 or small condenser mic) on a small stand for the didgeridoo and 1 x kick drum mic (Shure Beta 52A or similar), also on a small stand.
- \* We need 2 x Direct Injection boxes (DIs).
- \* We need 2 x XLR leads (we have our own DI or equipment for these).
- \* We require access to 2 power outlets for multiple equipment, we have our own four board adapters too. We assume you will already have power to the stage for the Monitors.
- \* We often travel with our own sound technician who knows our material and mixing requirements, but we will need a crew to set up and pack down the PA.