

Spiral Dance 5-Piece Stage Plan

Spiral Dance are:

Adrienne Piggott – lead vocals
Paul Angas - drums
Nick Carter – guitars; didgeridoo; vocals
Paul Gooding – button accordion; vocals
Nigel Walters – bass

Requirements:

3 x Vocal mics
1 x Kick Mic
2 x O/H Mics
2 x DI boxes
3 x XLR
3 x AC Power

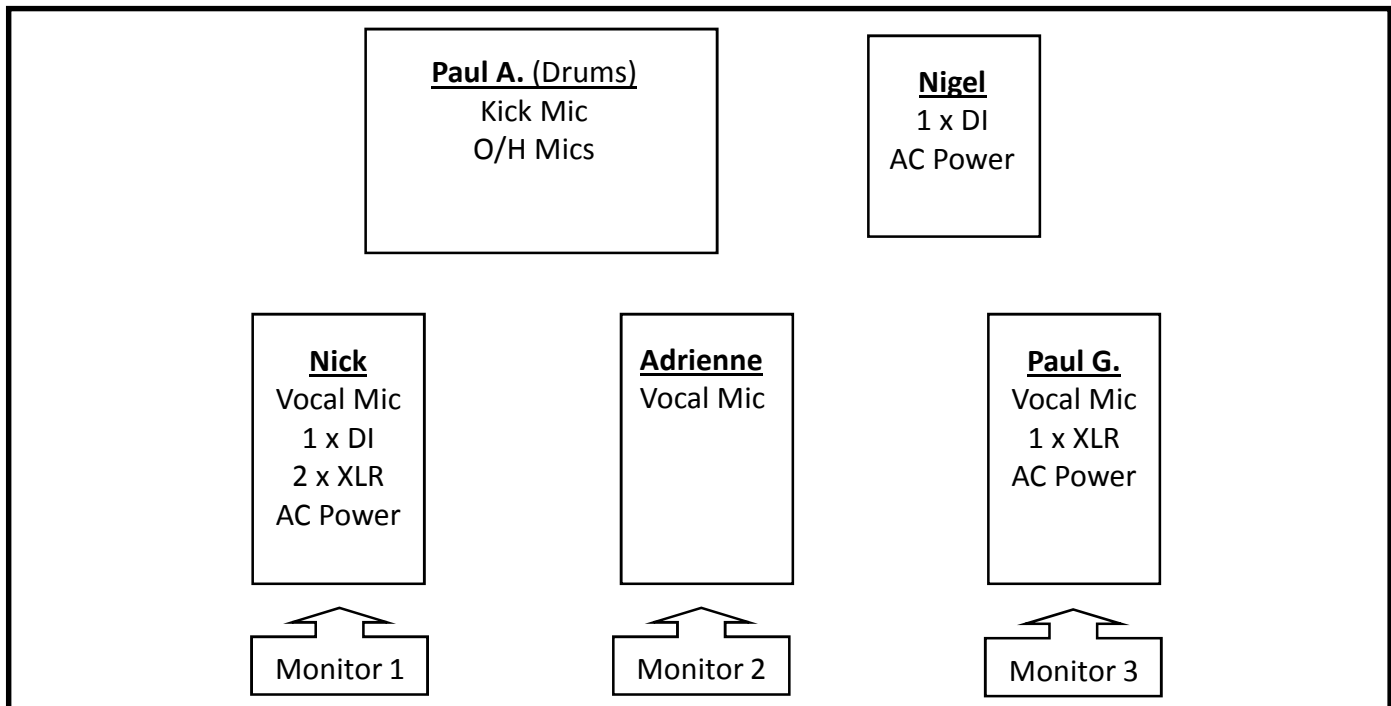

Front of Stage

YOUR PA SYSTEM:

- * We ideally need 11 inputs (as shown above).
- * Good monitoring is essential; we prefer 3 monitors with at least 2 separate sends. Our guitarist often uses In-Ear monitors and our drummer has his own small monitor.
- * 31 Band Graphic EQ for 2 sends and front of house...total of 3 EQs if not running in stereo.
- * Reverb effects are essential for vocals.
- * Microphones: we need 3 x Shure SM58 mics (or better) on stands for vocals, boom stands very much preferred. We also need 1 x kick drum mic (Shure Beta 52A or similar) and 2 x Overhead condenser mics, also on stands.
- * We need 2 x Direct Injection boxes (DIs).
- * We need 3 x XLR leads (we have our own DI or equipment for these).
- * We sometimes supply our own Bass Amp but run a line out of that for monitors and FOH.
- * We require access to 3 power outlets for multiple equipment, we have our own four board adapters too. We assume you will already have power to the stage for the Monitors.